

Parameter extraction of photovoltaic panels using genetic algorithm

K. Khelil, T. Bouadjila, F. Berrezek, T. Khediri
Univ. Souk Ahras, Fac. Sci & Tec.,
LEER Lab.,
Souk Ahras (41000), Algeria.
k_khelil@yahoo.fr, khaled.khelil@univ-soukahras.dz

Abstract—This paper examines the identification of photovoltaic (PV) module through Genetic Algorithm (GA) using a cost function based on, only, the electrical performance values of P_{max} , V_{mp} , I_{mp} , V_{oc} and I_{sc} provided by the manufacturer datasheet at Standard Test Conditions (STC). To extract the five electrical parameters of the considered single diode model, the approach is formulated as a non convex optimization problem, and the GA is employed to overcome the nonlinear and transcendental nature of the circuit model. Compared to data provided by various manufacturers, the obtained simulation results show that our proposed approach is very efficient in estimating the electrical parameters of PV solar modules.

Keywords— Photovoltaic (PV) module, parameter extraction, genetic algorithm, cost function.

I. INTRODUCTION

Recently, photovoltaic (PV) technology has received considerable attention because of its environmental and economic benefits. In a PV power generation system, due to the high cost of the PV modules and their low conversion efficiency, the exploitation of the available solar energy should be optimized. This could be ensured using an electric model that describes, accurately, the performance of a given photovoltaic system under different environmental conditions, which could be very helpful to predict the behavior of the maximum power tracker (MPPT) or to estimate the PV system efficiency. During the past few years, several research works have been carried out using the single and double diodes model [1]-[5]. The common and simple five parameter circuit-based model, shown in Fig. 1 and made up of series resistance R_s , parallel resistance R_p , saturation current I_o , photocurrent I_{pv} , and ideality factor n , has been successfully applied to describe the $I-V$ characteristic of PV modules [6]-[10]. However, such circuit model shows a transcendental function that exhibits nonlinear characteristics depending on the solar irradiation, and cell temperature [3], [4]. Moreover, it is necessary to correctly determine the five parameters of the one diode model, namely $\{R_s, R_p, I_o, I_{pv}, n\}$, otherwise an accurate simulation of the PV system could not be achieved.

In general, these parameters are estimated using two kinds of approach: (1) the analytical and (2) numerical techniques [2]. The analytical technique considers the solution of some equations, derived from specific selected points on the $I-V$

characteristic. Despite the simplicity of such method, its precision is highly related to the selected points on the $I-V$ curve. The second approach relies on fitting algorithms and has the advantage to fit all the points on the $I-V$ characteristic. Conversely, and besides the fact that such approach may lead to artificial solutions, its accuracy depends on the type of fitting algorithm and the cost function. Moreover, this kind of techniques uses all the experimental data, usually provided in data-sheets as $I-V$ curves, which are not, unfortunately, exact values. Thus, if one or more of the values, issued from $I-V$ curves, are wrongly specified, the errors in estimating the parameters may be significant. Recently, several evolutionary optimization algorithms, reported to be more promising than other conventional methods, among them genetic algorithm (GA) [2],[5], and particle swarm optimization (PSO) [11], have been adopted to solve the nonlinear problem of PV module parameter identification.

In this paper, a nonlinear least-squares optimization technique, based on genetic algorithm (GA), to extract the five electrical PV panel parameters $\{R_s, R_p, I_o, I_{pv}, n\}$ is proposed. The approach consists of optimizing a non-convex cost function expressed in terms of, only, the values of $\{P_{max}, V_{mp}, I_{mp}, V_{oc}, I_{sc}\}$ available in the manufacturer datasheet at STC conditions (*module temperature 25°C, irradiance 1kW/m², A.M1.5*).

The rest of this paper is organized as follows. Section 2 presents the one-diode model of a PV panel. The proposed approach to extract the five parameters is presented in Section 3. The obtained simulation results, using the proposed method, are shown and in Section 4. Finally, some concluding remarks are given in section 5.

II. MATHEMATICAL MODEL OF PV PANEL

Despite the fact that the diffusion and recombination currents are linearly independent, it is common to combine them together under the introduction of a nonphysical diode ideality factor n . Recently, the use of this single diode model to describe the static $I-V$ characteristic has been considered widely, and it has been used successfully to fit experimental data. The single diode model equivalent circuit is shown in Fig. 1 [5].

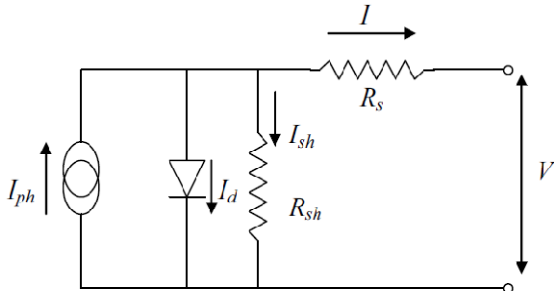

Fig. 1: Equivalent circuit of a single diode model.

In this model, Eq. (1) is reduced to the following equation

$$I = I_{ph} - I_o \left[\exp\left(\frac{V+IR_s}{nV_T}\right) - 1 \right] - \frac{V+IR_s}{R_{sh}} \quad (1)$$

For a photovoltaic panel comprising N_s cells in series, and assuming that all cells are identical and subjected to the same temperature and a uniform illumination:

$$I_{panneau} = I_{cellule} \text{ and } V_{panneau} = N_s \cdot V_{cellule}$$

In this work, three photovoltaic panels :MSX-60, MSX-64 and Kyocera KC200GT are used. The electrical characteristics, under standard test conditions (air mass 1.5, cell temperature = 25°C and irradiation = 1000W/m²) are given in Table 1, where I_{pv} and I_o are respectively the current generated by the incidence of light and the reverse saturation currents of the diode. Other variables are defined as follows: $V_T = N_s kT/qV_T$ is the thermal voltage of the PV module having N_s cells connected in series, q is the electron charge (1.60217646.10⁻¹⁹ C), k is the Boltzmann constant (1.3806503. 10⁻²³ J/K) and T is the temperature of the P-N junction in Kelvin.

Table I: Electrical characteristics of the three PV modules at STC.

	KC200GT	MSX-64	MSX-60
maximum power (P_{max})	200 W	64 W	60 W
maximum power voltage (V_{mp})	26.312V	17.5 V	17.1 V
maximum power current (I_{mp})	7.61 A	3.66 A	3.5 A
Short circuit current (I_{sc})	8.21 A	4.0A	3.8 A
Open circuit voltage (V_{oc})	32.9 V	21.3 V	21.1 V
Temperature Coefficient of V_{oc}	(-80 ± 10)mV/°C		
Temperature Coefficient of I_{sc}	(0.0065 ± 0.015)%/°C		
Temperature Coefficient of P_{max}	-(0.5 ± 0.05)%/°C		
Number of cells	36		

III. OPTIMIZATION METHOD USING GENETIC ALGORITHM

The Genetic algorithm (GA), is a well known method for solving both constrained and unconstrained optimization problems that is based on natural selection and natural genetics. Given a cost function J , and unlike many conventional optimization methods, which are generally single path searching algorithms, the GA starts searching from several points and evolves toward an optimal solution [2], [5].

In this work, the optimization process consists of solving equation (1) to determine the five parameters of the single

diode model. These parameters will be used to predict the values given by the manufacturer, i.e. the short-circuit current I_{sc} the open circuit voltage V_{oc} , the maximum power P_{max} the voltage at the maximum power V_{mp} and current of maximum power I_{mp} . The proposed objective function is the sum of the quadratic errors given by

$$J = (I_{sc} - \hat{I}_{sc})^2 + (V_{oc} - \hat{V}_{oc})^2 + (P_{max} - \hat{P}_{max})^2 + (V_{mp} - \hat{V}_{mp})^2 + (I_{mp} - \hat{I}_{mp})^2 \quad (2)$$

Where $\{\hat{I}_{sc}, \hat{V}_{oc}, \hat{P}_{max}, \hat{V}_{mp}, \hat{I}_{mp}\}$ are the predicted values of the short circuit current, the open circuit voltage, the maximum power, the maximum power voltage and the current at maximum power respectively.

Hence, using the cost function J , an outline of the genetic algorithm for the optimisation proceeds as follows:

1) Initial population

A random initial population chromosome is generated. Each chromosome is a string in the form $\{I_{ph}, I_o, R_s, R_{sh}, n\}$. According to the literature related to the field of PV panel modeling, intervals of five parameters are chosen as follows:

- $I_{sc} - 1 \leq I_{ph} \leq I_{sc} + 1$
- $10^{-8} \leq I_o \leq 10^{-7}$
- $0.05 \leq R_s \leq 2$
- $100 \leq R_{sh} \leq 1000$
- $1 \leq n \leq 1.5$

2) Fitness function

a) Solve the nonlinear equation:

Each chromosome is replaced in:

$$I = I_{ph} - I_o \left[\exp\left(\frac{V+IR_s}{nV_T}\right) - 1 \right] - \frac{V+IR_s}{R_{sh}}$$

The equation is solved using the Newton-Raphson method for solving non-linear equations to determine the $I - V$ and $P - V$ characteristics of the module.

b) Parameter estimation

From the $I-V$ and $P-V$ characteristics determined in step 2, the values of $\{\hat{P}_{max}, \hat{V}_{mp}, \hat{I}_{mp}\}$ are extracted and the values of $\{\hat{I}_{sc}, \hat{V}_{oc}\}$ are interpolated to end up with the five estimated parameters:

$$\{\hat{I}_{sc}, \hat{V}_{oc}, \hat{P}_{max}, \hat{V}_{mp}, \hat{I}_{mp}\}$$

c) Evaluation of the objective function

Using the objective function given in "(2)," evaluate the cost J for each chromosome (individual) in the population and assign to it a numerical value reflecting its quality as a potential solution.

3) Creating the next generation

At each step, the genetic algorithm uses the current population to create the children that makes up the next generation. The algorithm selects a group of individuals in the

current population, called parents, who contribute their genes (entries of their vectors) to their children. The algorithm selects individuals that have better fitness values of parents.

In total, three types of children are generated:

a) *Elite children*

are the individuals in the current generation with the best fitness values. These individuals automatically survive to the next generation.

b) *Crossover children*

are created by combining the vectors of a pair of parents. Scattered crossover with a crossover fraction equals to 0.8 is used in this paper. Scattered crossover creates a random binary vector and selects the genes where the vector is a 1 from the first parent and the genes where the vector is a 0 from the second parent, and combines the genes to form the child.

c) *Mutation children*

are created by introducing random changes, or mutations, to a single parent. In this work we have employed Gaussian mutation where a random number is added to each vector input of an individual, which is taken from a Gaussian distribution centred at zero.

The above process is repeated until terminal conditions are satisfied; we denote the best chromosome as a solution, which is regarded as the optimal solution of the optimization problem. Fig. 2 shows the block diagram of the GA optimization process.

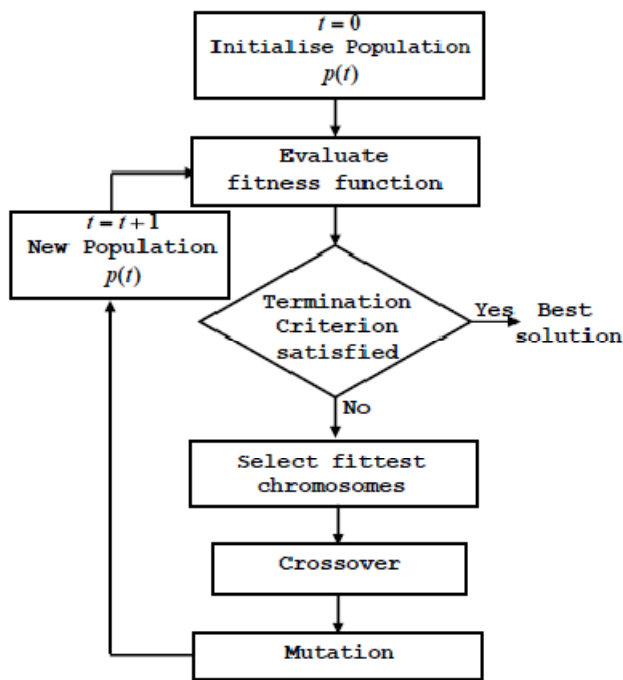

Fig. 2 Genetic algorithm flowchart.

IV. SIMULATION RESULTS

In order to verify the performance of the proposed method, the genetic algorithm is executed 100 times to estimate the five parameters $\{\hat{I}_{sc}, \hat{V}_{oc}, \hat{P}_{max}, \hat{V}_{mp}, \hat{I}_{mp}\}$. Compared to those

available in the manufacturer datasheet, the set of the five extracted parameters having the least square error, is considered to be the optimal solution of the problem. The obtained results are reported in Tables II-IV for the three considered PV modules. It is noticeable that the obtained values are very close to those given by the manufacturers with a mean square error of about 0.0005, 0.0007 and 0.0021 for *MSX-60*, *MSX-64* and *Kyocera KC200GT* solar panels respectively.

Table II. The five predicted parameters using GA with those given by the manufacturer of the *MSX-60* PV module.

<i>MSX-60</i>		
	<i>Manufacturer</i>	<i>GA</i>
Maximum power (P_{max})	60 W	60.028 W
Maximum power voltage (V_{mp})	17.1 V	17.066 V
Maximum power current (I_{mp})	3.5 A	3.517 A
Short circuit current (I_{sc})	3.8 A	3.800 A
Open circuit voltage (V_{oc})	21.1 V	21.082 V

Furthermore, to show the efficiency of the proposed optimization approach, the I-V characteristics of the *MSX-60*, *MSX-64* and *KC200GT* PV modules, obtained using the five estimated parameters, and those available in the manufacturer datasheets are plotted in Figs. 3- 8. Comparing the curves corresponding to each PV module, it is clear that they reveal almost the same characteristics.

Table III. The five predicted parameters using GA with those given by the manufacturer of *MSX-64* PV module.

<i>MSX-64</i>		
	<i>Manufacturer</i>	<i>GA</i>
Maximum power (P_{max})	64 W	64.034 W
Maximum power voltage (V_{mp})	17.5 V	17.462 V
Maximum power current (I_{mp})	3.66 A	3.667 A
Short circuit current (I_{sc})	4 A	3.997 A
Open circuit voltage (V_{oc})	21.3 V	21.271 V

Table IV. The five predicted parameters using GA with those given by the manufacturer of *Kyocera KC200GT* PV module.

<i>KC200GT</i>		
	<i>Manufacturer</i>	<i>GA</i>
Maximum power (P_{max})	200 W	200.06 W
Maximum power voltage (V_{mp})	26.3	26.231 V
Maximum power current (I_{mp})	7.61	7.626 A
Short circuit current (I_{sc})	8.21	8.207 A
Open circuit voltage (V_{oc})	32.9 V	32.890 V

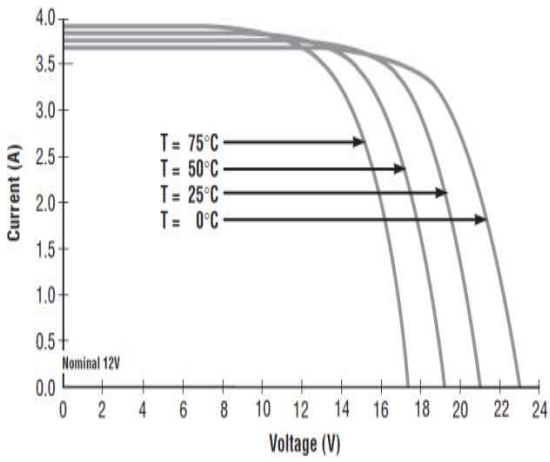

Fig. 3. The MSX-60 PV module I-V characteristic of the manufacturer.

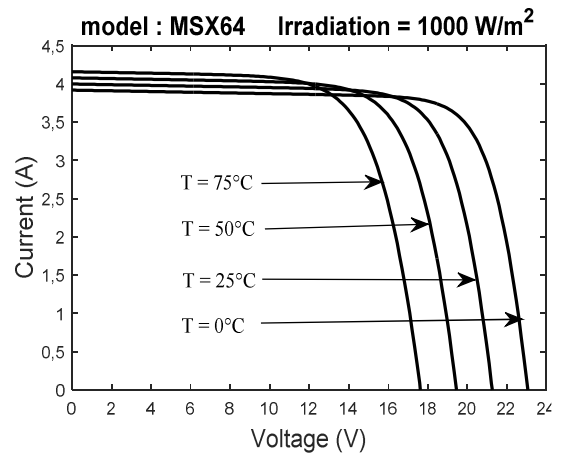

Fig. 6. The MSX-64 PV module I-V characteristic estimated using GA algorithm.

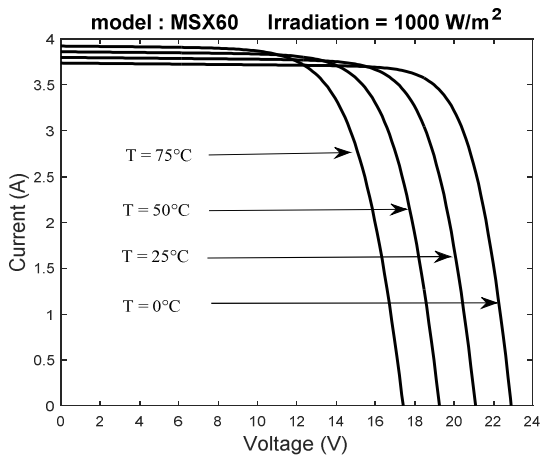

Fig. 4. The MSX-60 PV module I-V characteristic estimated using GA algorithm.

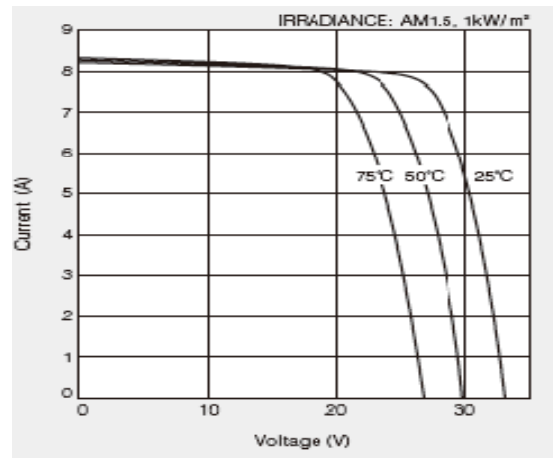

Fig. 7. The Kyocera KC200GT PV module I-V characteristic of the manufacturer.

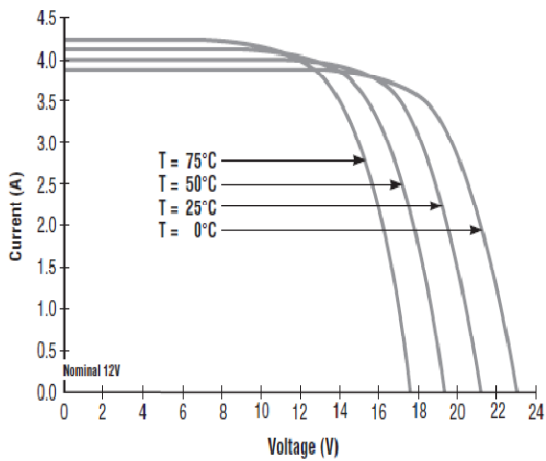

Fig. 5. The MSX-64 PV module I-V characteristic of the manufacturer.

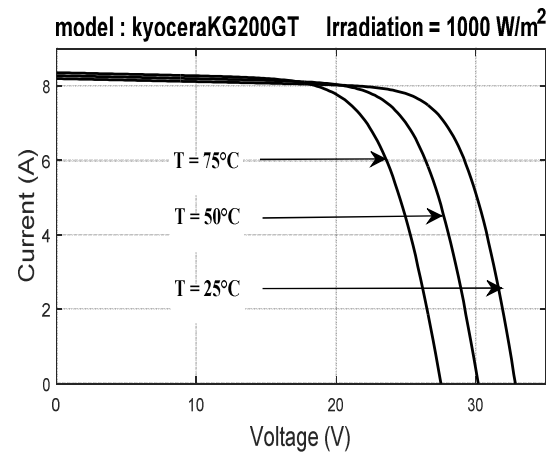

Fig. 8. The Kyocera KC200GT PV module I-V characteristic estimated using GA algorithm.

V. CONCLUSION

In this paper, the extraction of the five parameters of the one diode model is performed using genetic algorithm and exploiting only the typical electrical characteristics given by the PV panel manufacturer. Alternatively, the parameter

estimation process is a GA based optimization problem minimizing an objective function employing only the values of P_{max} , V_{mp} , I_{mp} , V_{oc} and I_{sc} available in the PV module datasheet. The obtained simulation results confirm the convenience of the proposed objective function leading to efficient PV module identification.

References

- [1] Chan, D.S.H., Phang, J.C.H., Analytical methods for the extraction of solar-cell single- and double-diode model parameters from I-V characteristics", *Electron Devices IEEE Transactions on* 34 (2), 1987, 286-293.
- [2] Kashif Ishaque, Zainal Salam, Hamed Taheri, Amir Shamsudin, "A critical evaluation of EA computational methods for Photovoltaic cell parameter extraction based on two diode model", *Solar Energy* 85, 2011 1768–1779.
- [3] Kashif Ishaque, Zainal Salam, Hamed Taheri, "Simple, fast and accurate two-diode model for photovoltaic modules", *Solar Energy Materials & Solar Cells* 95, 2011, 586–594.
- [4] A.M. Humada, M. Hojabri, S. Mekhilef, H.M. Hamada, "Solar cell parameters extraction based on single and double-diode models: a review", *Renew. Sustain. Energy Rev.* 56, 2016, 494-509.
- [5] S.J. Patel, A.K. Panchal, V. Kheraj, "Solar cell parameters extraction from a current-voltage characteristic using genetic algorithm", *J. Nano Electron. Phys.* 5 (2), 2013, 5-7.
- [6] T.U. Townsend, "A Method for Predicting the Long-Term Performance of Directly-Coupled Photovoltaic Systems", University of Wisconsin, Madison, 1989.
- [7] J.A. Duffie, W.A. Beckman, *Solar Engineering of Thermal Processes*, 2nd ed., JohnWiley & Sons, Inc., New York, 1991.
- [8] W. DeSoto, S.A. Klein, W.A. Beckman, "Improvement and validation of a model for photovoltaic array performance", *Solar Energy* 80, 2006, 78–88.
- [9] L.B. Valerio, A. Orioli, G. Ciulla, A. Di Gangi, "An improved five-parameter model for photovoltaic modules", *Solar Energy Materials and Solar Cells* 94, 2010, 1358–1370.
- [10] M.T. Boyd, S.a. Klein, D.T. Reindl, B.P. Dougherty, "Evaluation and validation of equivalent circuit photovoltaic solar cell performance models", *Journal of Solar Energy Engineering* 133, 2011.
- [11] Q. Hengsi, J.W. Kimball, "Parameter determination of photovoltaic cells from field testing data using particle swarm optimization", *Power and Energy Conference at Illinois (PECI)*, IEEE, 2011, 1-4.